

# Facts Underlying the Ultra-high Precision of the VERA Antennas

VERA is an acronym for “VLBI Exploration of Radio Astrometry.” VERA uses the relative VLBI method to triangulate maser source positions within the Milky Way Galaxy with a precision 100 times better than ever before. This project aims to draw a three-dimensional map of the Milky Way. Researchers in various fields from many universities and research institutions are participating in this project, with the National Astronomical Observatory of Japan playing a central role. VERA uses a type of radio interferometry called VLBI (Very Long Baseline Interferometry) to combine observations from 20 meter diameter radio telescopes stationed at four sites throughout Japan (Mizusawa, Iriki, Ogasawara, and Ishigaki-jima) to provide a resolution equivalent to that of a 2,300 km diameter radio telescope. Such precision provides a position determination accuracy equivalent to the size of a one-yen coin on the surface of the Moon when viewed from the Earth.

A major feature of VERA is its specialization in the relative VLBI observation technique.

With standard observation methods, atmospheric fluctuations make it impossible to accurately measure the positions of stars. In the VERA system, two close together objects are observed simultaneously to compensate for atmospheric fluctuations, enabling precision position measurements. VERA conducts relative VLBI efficiently through the use of “dual-beam antennas.” One of these antennas can observe 2 objects up to 2 degrees apart simultaneously with the 2 pairs of receivers installed at the focal point. VERA was the first in the world to attempt observations with this kind of dual-beam antenna. Think about the secrets behind this high-precision as you make your own radio telescope paper model.

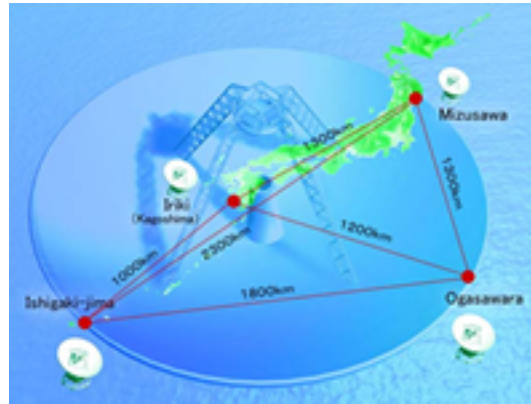

20-m Radio Telescope at the Ishigaki-jima Station

The mirror surface accuracy of the 20-m antenna is maintained to 250  $\mu\text{m}$  or less, allowing the antenna to efficiently capture radio waves of up to 43 GHz. Weighing 380 tons, with a survival wind speed of 90 m s<sup>-1</sup>, it's well equipped for the weather of Ishigaki-jima, known to be a busy typhoon pathway.

## Dual-beam receivers →

To simultaneously observe two objects, one pair of receivers is equipped for each of the 22 GHz and 43 GHz frequencies. The positions of these receivers can be adjusted three-dimensionally in order to observe various pairs of objects. Also, in order correct for field rotation caused by the diurnal motion of celestial objects, the entire platform rotates.



Designed by Seiichi Sakamoto (NAOJ)

# VERA Antenna Paper Model Construction Project for a Child with Adult Assistance, Expert Course (Crafting Instructions 1)

Tools and materials: box cutter, glue (wood glue works well)

1. Preparation: Copy the three paper model cutout sheets onto Kent paper or similar thick paper, scaled so that the dimensions of the outer edge of each copy is 17 cm × 26.5 cm, and cut out all 33 model parts by cutting along the bold lines. The nine parts with an asterisk (\*) by their name labels can be omitted if work time is limited. Next, make incisions and cut out the holes indicated by an "X" by cutting along the bold lines. Mountain-fold along the dot-dash lines, and valley-fold along the dashed lines. Note that thin dotted lines indicate an overlap width for gluing parts together and should not be creased.



↑ Photo showing the parts after being cut out and folded

2. Assemble the feedome: Curl the feedome side into a ring, and then attach the feedome top from inside to form a shape like Mt. Fuji.

3. Assemble the subreflector: Crimp the subreflector into a convex shape with your fingernails. Attach the subreflector to the tip of the triangular pillar shaped subreflector drive, and then glue the subreflector stays to the subreflector drive so that they wrap around the three sides of the drive to form a tripod structure. When assembling the tripod structure, make sure the subreflector faces downward.

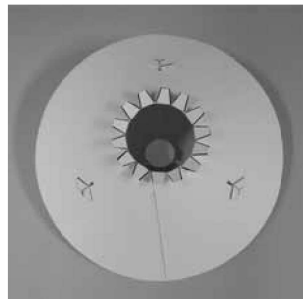

4. Assemble the main reflector : Form the main reflector into a horn shape with the printed surface facing inward, and insert the legs of the secondary mirror stays into the three slits; then glue them in place from the back side.

5. Assemble the main reflector back-up structure: Form the main reflector back-up structure into a horn shape with the printed surface facing outward. Next glue the part labeled "main reflector back-up structure outer edge" to the main reflector back-up structure so that the side labeled "main reflector side" faces outwards and the seams of the overlap tabs for gluing on both parts are aligned.

6. Assemble the center hub and receiver cabin: Curl the receiver cabin side into a cylindrical shape. Guide the elevation axes through the holes from inside, and then glue them together. Referring to the photo, glue the receiver cabin bottom to the bottom side (the side closer to the elevation axis); then glue the center hub bottom to the outside at a position a little higher than the elevation axis. After that, glue the field rotator base to the top of the assembly. Fold the mobile receiver platforms to form an "M" shape and attach them to the field rotator platform. Fold the four tabs of the field rotator platform downward, and insert them in the hole of the field rotator base (do not glue them). Curl the center hub side into a cylindrical shape and glue the top on it. Put it over the receiver cabin's top part, and glue it to the center hub bottom.

7. Attach the sector gear: Glue together the two sector gear parts, and then glue them to the receiver cabin side and center hub bottom.

8. Assemble the mount: Assemble the lower instrument cabin to form a bottomless box. Attach the elevation drive to the second-floor part. Assemble the mount except for the front side (bottom-side portion of the model cutout), and glue the lower instrument cabin to the first floor of the mount at the marked areas. To attach the second-floor part, first glue its front (concave) edge to the overlap width on the front side of the mount; then assemble the front side of the mount. Form the azimuthal drive wheels into wedge shapes and then attach them, facing downward, to the backs of the marked areas in the four corners of the mount first floor.

9. Assemble the base: Glue the azimuth axis at the center of the base.



↑ Photo showing all of the units which are now almost completed.

# VERA Antenna Paper Model Construction Project for a Child with Adult Assistance, Expert Course (Crafting Instructions 2)

10. Assemble entire model: Guide the receiver cabin's elevation axis through the elevation axis bearings on the mount (do not glue), and then insert the sector gear into the slit in the elevation drive on the mount. Glue together the main reflector and main reflector back-up structure so that the positions of the subreflector stay's legs and the positions of the main reflector back-up structure's subreflector support pillars are aligned, and the main reflector structure forms a single-piece unit. Attach this main reflector structure to the top portion of the center hub so that the subreflector stays form an inverted-Y shape when viewed from the front. Be careful not to apply glue to the four slits. Insert the feedome's four tabs into these four slits (do not glue). Finally, place the radio telescope on the top of its base to finish assembly.



The subreflector stays form an inverted-Y shape when viewed from the front.

Do not apply glue to the feedome.

The side with the concave second-floor part is the front of the mount.

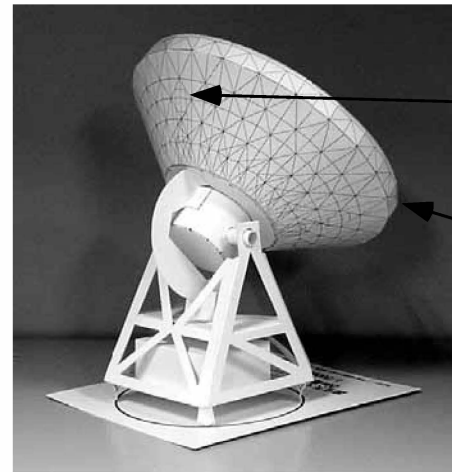
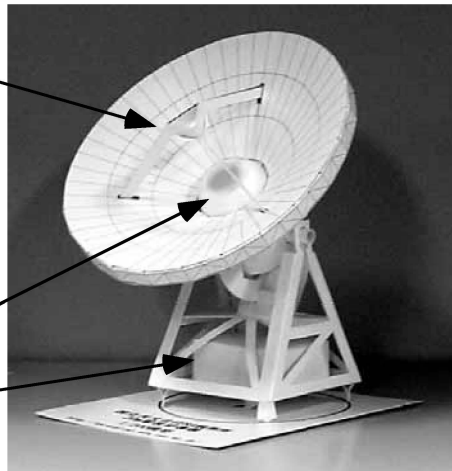

The subreflector support pillars also form an inverted-Y shape when viewed from the back.

The main reflector back-up structure and the back-up structure outer edge should be aligned to form intersections where 8 pillars converge.

The dual-beam receivers can be seen on the mobile receiver platforms when the feedome is removed; thus, the space between the receivers can be changed, and the receivers can be rotated as well.

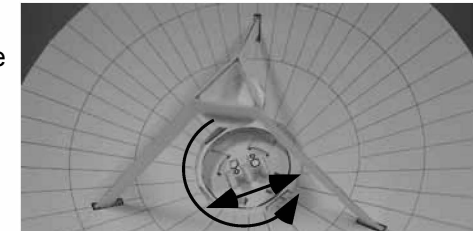

# VERA Antenna Paper Model Construction Project for a Child with Adult Assistance Expert course (1/3)

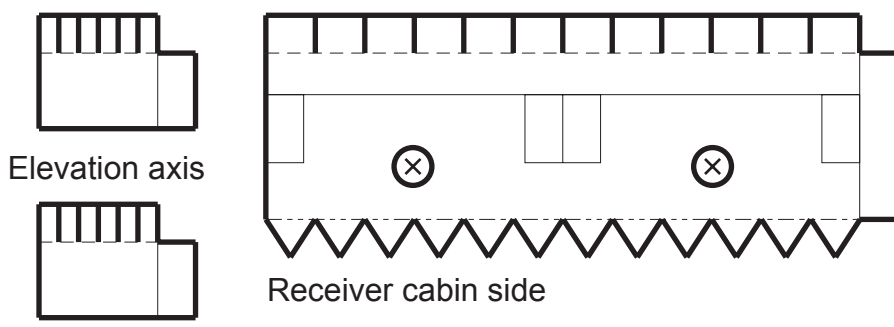
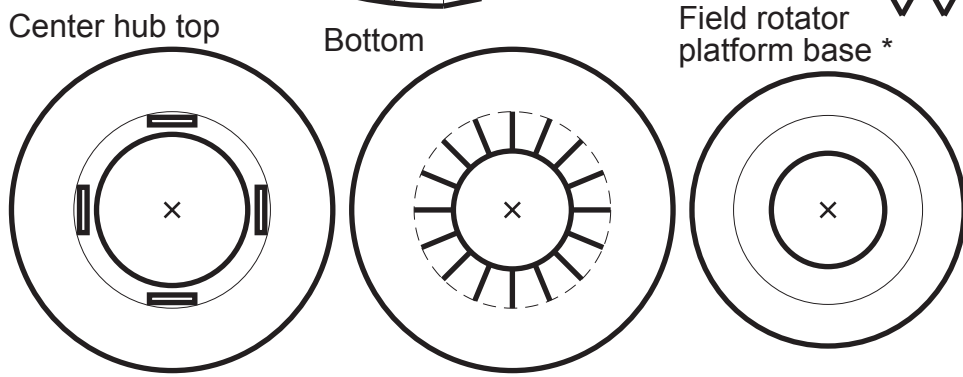
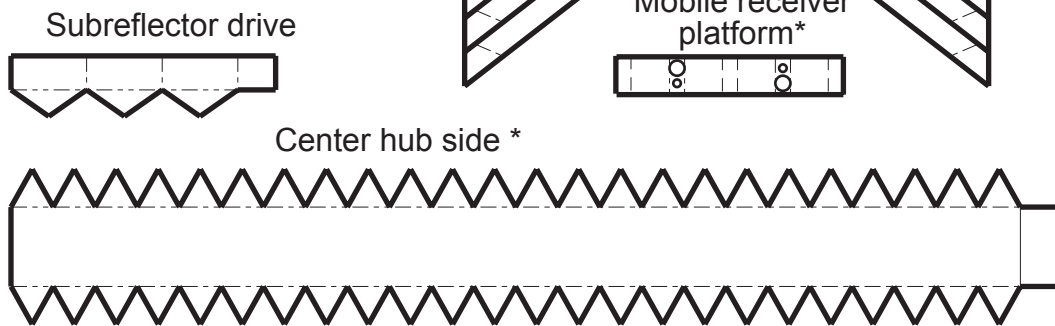
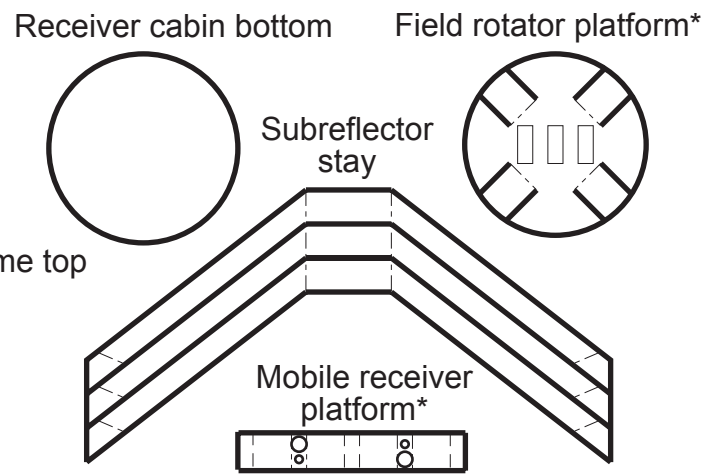
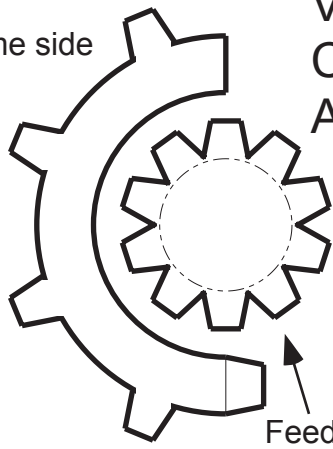
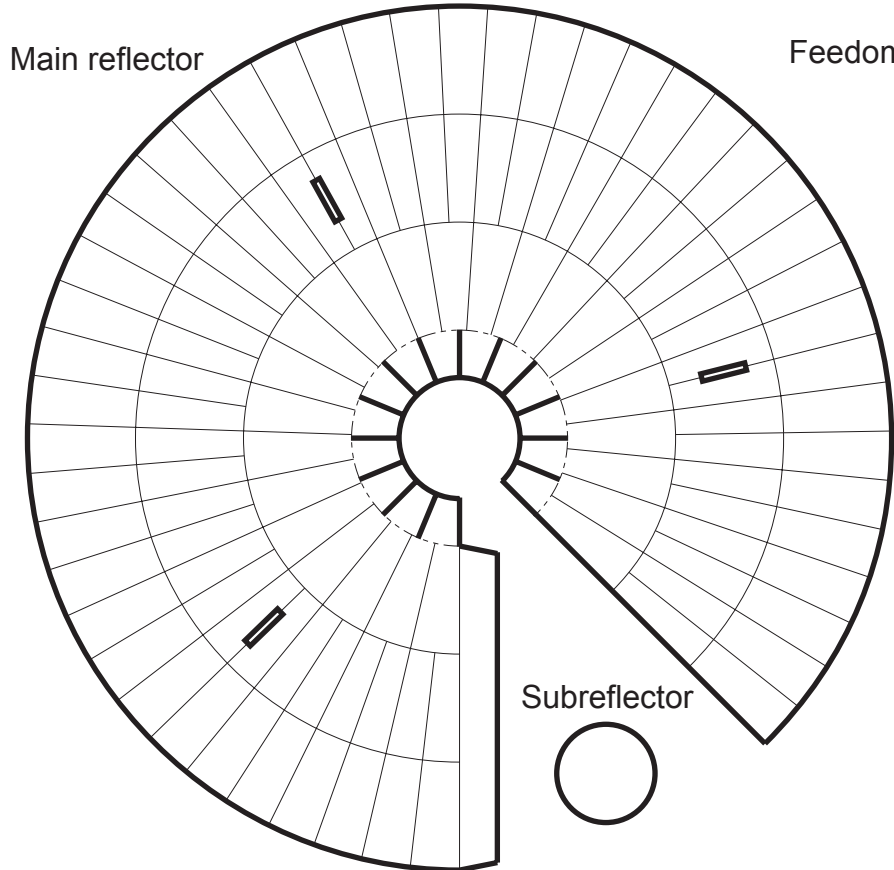

# VERA Antenna Paper Model Construction Project for a Child with Adult Assistance Expert course (2/3)

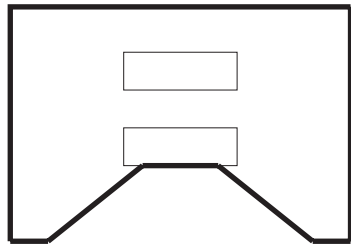

Second floor part

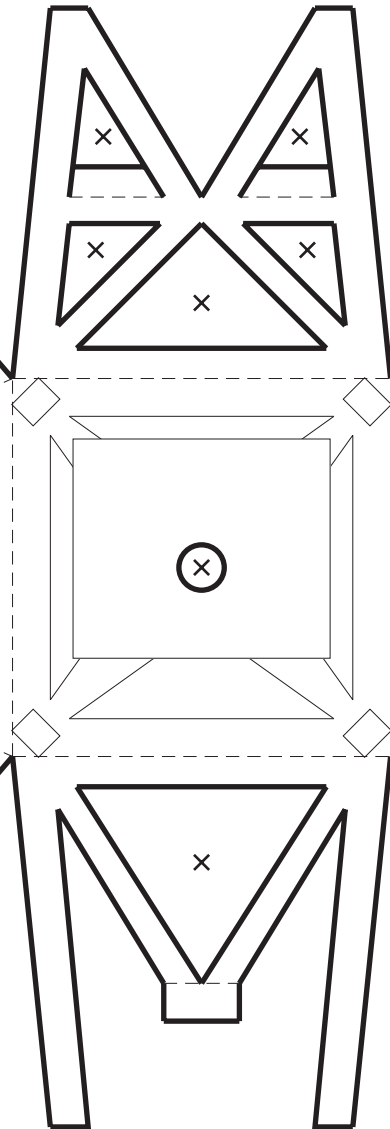

Mount

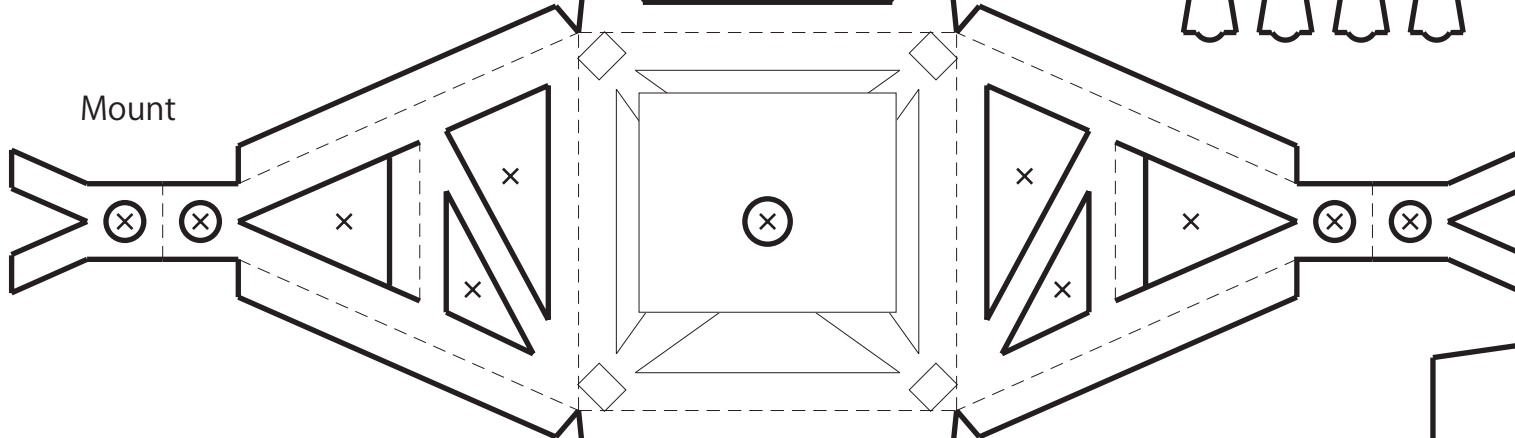

Sector gear

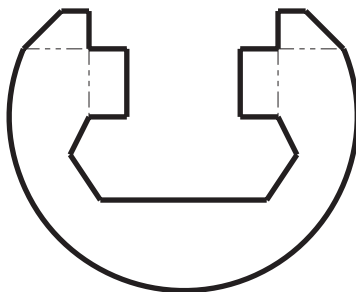

Sector gear

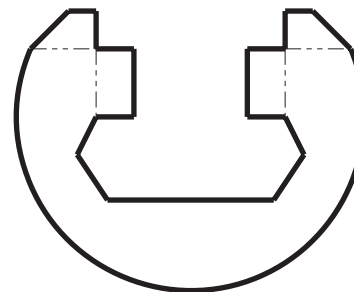

Azimuth drive wheels \*

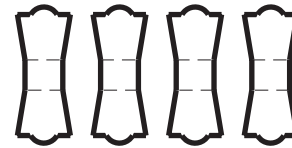

Elevation drive

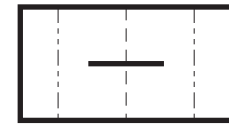

Lower instrument cabin

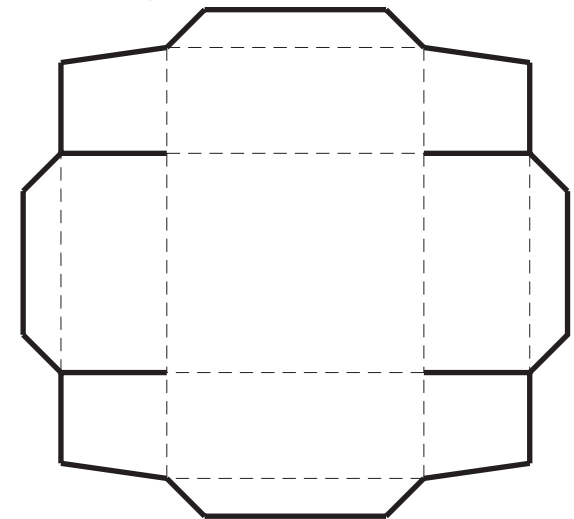

# VERA Antenna Paper Model Construction Project for a Child with Adult Assistance Expert course (3/3)

Main reflector  
back-up structure

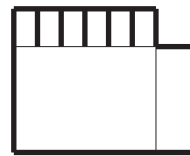
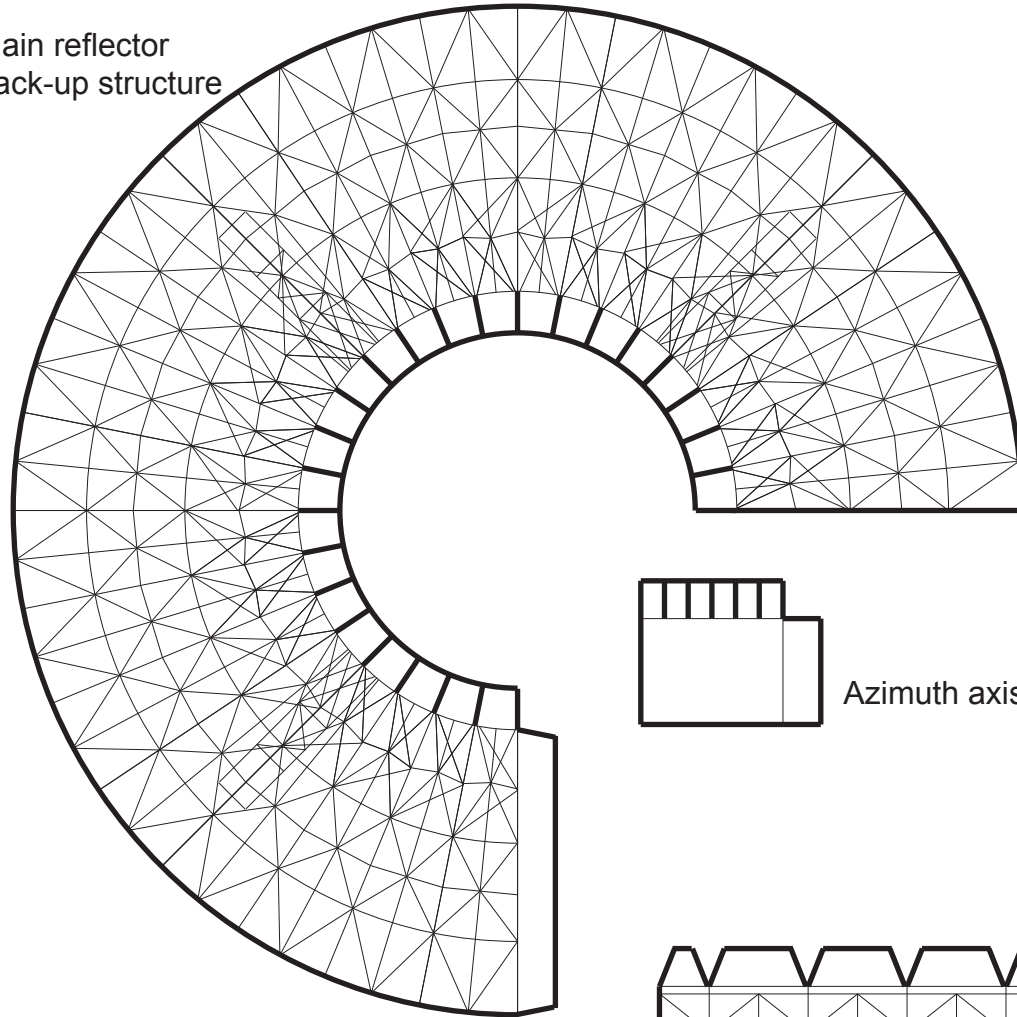

Azimuth axis \*

Base

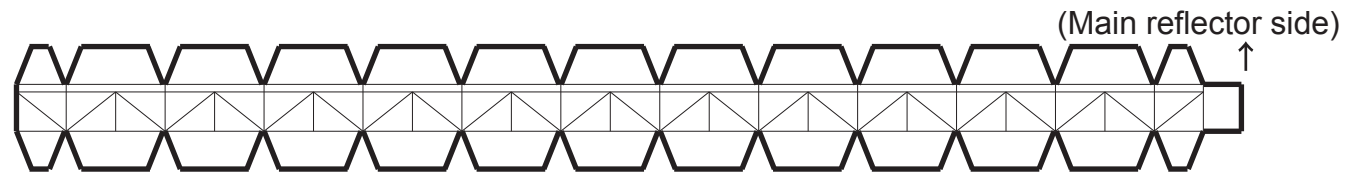
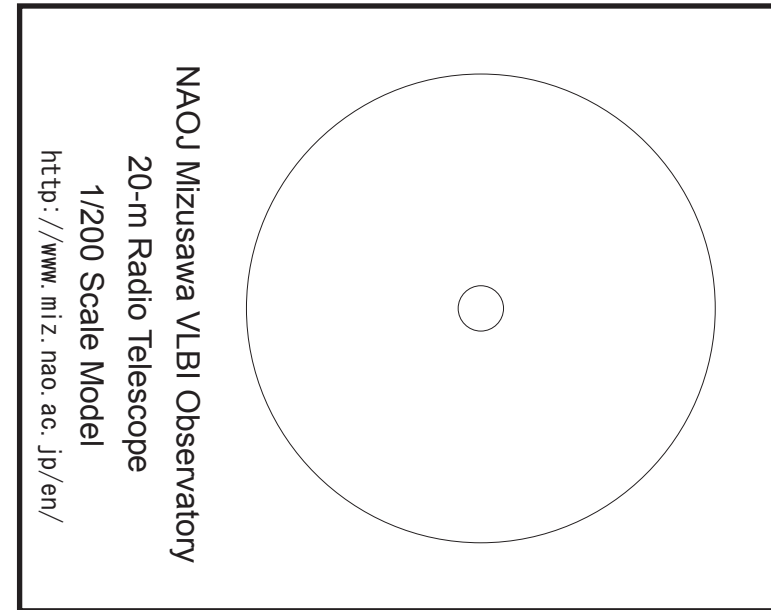

Main reflector back-up structure

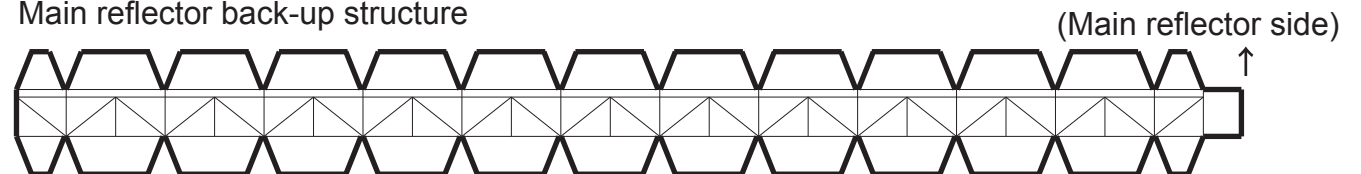

# Telescope Fun Facts

## “De-twinkling” the Stars

Unlike the Hubble Space Telescope and other telescopes in space, large terrestrial telescopes such as VERA, the Subaru Telescope, and ALMA are influenced by absorption (light reduction) and atmospheric fluctuations due to the Earth’s atmosphere. Atmospheric fluctuations cause the twinkling of the stars and heat haze shimmering, which may blur obtained images, give inaccurate star locations, etc. Because of this, various measures (referred to as phase correction methods) are taken in order to eliminate these effects. The typical methods are introduced below, using the VERA antennas as examples.

### 1. Method to directly detect star twinkling and remove it

#### 1.1 Self-calibration method

By monitoring a small, bright object in the telescope’s field of view and observing the target object for shorter intervals than the speed of the reference object’s twinkling, the twinkling of the stars can be eliminated.

The wavefront compensation method used by optical/infrared telescopes like the Subaru Telescope is also based on this principle of utilizing a guide star within the field of view.

#### 1.2 Paired antenna method

Generally, there are not many cases where a small and sufficiently bright object can be found within the field of view. Using two antennas as a pair, one of them observing the target object while the other one observes a nearby reference object, provides a similar effect. In VERA, each antenna is equipped with two pairs of receivers, which are independently controlled to simultaneously observe two objects, thus achieving the same effect.

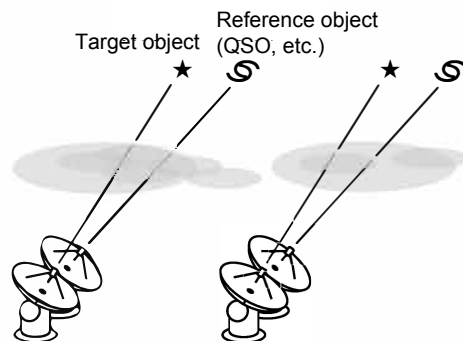

#### 1.3 Fast-switching method

The fast-switching method performs observations of two objects with one antenna, switching the field of view between them at a high speed to produce the same effect. The ALMA (Atacama Large Millimeter/ Submillimeter Array) antennas use this method combined with the radiometer method (described below). Since the ALMA antennas perform observation at extremely high radio frequencies, the number of objects that are sufficiently strong to serve as reference

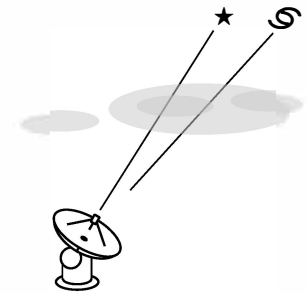

objects at those frequencies is extremely limited. Because of this, ALMA uses the following method as well: observing a reference object at a low frequency of about 100 GHz; converting the measured twinkling speed to the corresponding speed at the observation frequency for the main target; and using the converted twinkling frequency for correction.

### 2. Methods to estimate and correct phase fluctuation

#### 2.1 Radiometer method

In radio wave observations, the main reason stars twinkle is water vapor. If the amount of water vapor can be measured by some means, then the effects from the stars twinkling can be removed. The radiant intensity of water vapor emission lines at 183 GHz and 22 GHz frequencies, and the radiant intensity of infrared rays near 10 μm are used to estimate the amount of water vapor.

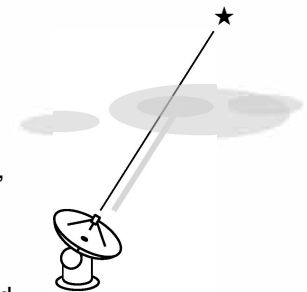

### 3. Technique to facilitate phase fluctuation correction

For multi-element radio interferometers, it is also possible to use an antenna array that makes the correction of atmospheric fluctuation effects easier (e.g., an array where the antenna baseline redundancy has been intentionally increased).