

# Temperature Control for the Primary Mirror of Subaru Telescope using the Data from ‘Forecast for Mauna Kea Observatories’

Akihiko MIYASHITA, Ryusuke OGASAWARA\*, George MACARAYA†, and Noboru ITOH†

(Received March 28, 2003)

## Abstract

Based on the successful numerical weather forecasting performed by collaboration between the Mauna Kea Weather Center and Subaru Telescope, we developed a temperature control system for the primary mirror of the Subaru Telescope. Temperature forecast is accurate 80% in 2 degrees. After the start of operation, the temperature of the primary mirror controlled below 1 degree centigrade compared by the ambient night air temperature in over 70% probability. The effect of the temperature control for the improvement of the seeing of Subaru telescope seems to be moderately effective. The median of the seeing size of Subaru Telescope on May 2000 to March 2003 is 0.655 arcsec FWHM. We need further investigation as to whether the improvement is the result of our successful temperature control system of the primary mirror or the effect of the annual variation of seeing itself. Thus, we need a longer period of data for verification of the effectiveness of the temperature control.

Key words: Subaru Telescope, Weather forecast, Seeing, Primary mirror, Temperature control.

## 1. Introduction

In order to obtain high quality images from optical-infrared telescope, the heat generated by the instruments and equipment need to be removed. Especially the temperature of the primary mirror should be lower than its ambient air temperature. A 62-cm active optics telescope model with a Shack-Hartmann wavefront analyzer was used to measure the mirror seeing effect for the study of Subaru Telescope Project by Iye et al. 1990. The degradation of the imaging quality due to the generation of microthermal convection was quantitatively evaluated from diurnal monitoring measurements over 90 days and nights. The dependence of mirror seeing on the temperature difference between the mirror and the ambient air and the effect of Flushing flow to blow away the microthermal turbulence were measured (Iye et al. 1991).

Implementation of a cooling system underneath the 8.3 m primary mirror of the Subaru Telescope is ideal for controlling the primary mirror temperature. However, it would be a very sophisticated system. Remaining night-time temperature is so stable as to be within 1 degree centigrade over an entire night for almost all cases, we have adopted the following method to control the primary mirror temperature at night-time.

In the day-time, the dome-air-conditioning system is active to keep the temperature of the observing space (telescope tube and Cassegrain instrument) at the predicted night-time temperature. In addition to this, the smaller enclosed space including the primary mirror is especially air-conditioned by a cell-air-conditioning system. Its temperature may be set by 2 degrees centigrade below the predicted night-time temperature. In the evening before observation, the mirror cover is opened and the primary mirror is exposed to the natural air. We expected primary mirror temperature may be kept below

the actual night-time temperature over the entire night.

The predicted temperature by Mauna Kea Weather Center is used as a target temperature of the air-conditioning systems. After a preliminary test run of our method, it was found to be satisfactory. Thus we started to operate the temperature control of the M1 since May 2000.

The statistics on seeing size for after May 2000 seems to be improved by the amount of 0.1 arcsec.

## 2. Forecast for Mauna Kea Observatories

The Mauna Kea Weather Center (MKWC) has been established as an infrastructure of Mauna Kea Observatories in January 1998. The purpose of MKWC is primarily to develop an accurate local weather forecasting. For this purpose, Mauna Kea Observatories and Institute for Astronomy, University of Hawaii began a research project in conjunction with Meteorology department of University of Hawaii. After several months of basic study, we found it would be advantageous to utilize a numerical weather forecasting, focused at the local terrain at the summit of Mauna Kea.

MKWC developed an accurate numerical weather forecasting system with horizontal resolution of 1 km and vertical resolution of 1 km at the top of Mauna Kea. The regional meso-scope model, MM5, is used based on the large scale numerical result based on AVN model performed by National Weather Center, Washington D. C. At 14:00 every afternoon, 48 hours of results of AVN computation becomes available to prepare the boundary conditions for MM5 computation for the next 48 hours. It takes several hours for the interpolation and data preparation. The MM5 computation had been carried out on the Fujitsu VPP700 vector parallel processors until 2001 February, then it is running on the Fujitsu Prime Power 2000 Scalar parallel processors of Subaru Telescope every day. The job for numerical weather forecasting begins around 20:00 at night, and ends 5:00 am. Then, according to the result of computation, wind direction, wind speed, temperature, and seeing values are estimated by the morning weather forecasting in the

\* Subaru Telescope, National Astronomical Observatory of Japan, 650 North Aohoku Place, Hilo, HI 96720 U.S.A.

† Mitsubishi Electric and Electronics USA, Subaru Telescope Engineering Office 120 Pauahi St. Rm. 310, Hilo, HI 96720 U.S.A.

Table 1. An example of ‘Forecast for Mauna Kea Observatories’ issued at 10 a.m. by Mauna Kea Weather Center: website (URL <http://hokukea.soest.hawaii.edu/forecast/mko/>).

Latest Forecast for Mauna Kea Observatories 10 a.m. HST (2000UTC) Monday 6 November 2000

3-day Forecast of Key Variables	2 p.m. HST	8 p.m. HST	2 a.m. HST	2 p.m. HST	2 a.m. HST	2 p.m. HST	2 a.m. HST
	Mon 06 Nov	Mon 06 Nov	Tue 07 Nov	Tue 07 Nov	Wed 08 Nov	Wed 08 Nov	Thu 09 Nov
	0000 UTC Tue 07 Nov	0600 UTC Tue 07 Nov	1200 UTC Tue 07 Nov	0000 UTC Wed 08 Nov	1200 UCT Wed 08 Nov	0000 UTC Thu 09 Nov	1200 UTC Thu 09 Nov
Precipitable Water (mm, summit upward)	1.5 to 1.8	0.7 to 0.9	0.5 to 0.7	2.0 to 2.3	1.0 to 1.3	2.0 to 2.3	1.7 to 2.0
Summit Temperature ( )	2 to 3	-3 to -2	-3.5 to -2.5	-0.5 to 0.5	-1 to 0	-0.5 to 0.5	-2 to -1
Wind Dir/Speed (mph)							
Summit	E/10-20	ENE/10-20	ENE/10-20	ENE/12-25	ENE/10-20	ENE/5-15	NNE/5-15
19,000 ft (500 hPa)	NNW/14	NNW/14	N/12	N/8	NNW/10	WNW/9	WNW/12
24,500 ft (400 hPa)	NNW/28	NNW/29	NNW/30	NW/25	NW/16	W/21	WSW/23
31,000 ft (300 hPa)	NNW/32	NNW/34	NW/37	NW/25	WNW/25	W/40	W/34
35,000 ft (250 hPa)	NW/35	NW/37	NW/33	WNW/26	W/29	W/46	W/49
40,000 ft (200 hPa)	NW/39	NW/36	WNW/32	WNW/28	W/33	W/47	W/63
46,000 ft (150 hPa)	NNW/35	NW/30	WNW/22	W/23	W/32	W/44	W/55
54,000 ft (100 hPa)	NNE/23	N/18	N/14	WNW/9	WSW/11	W/24	WNW/27

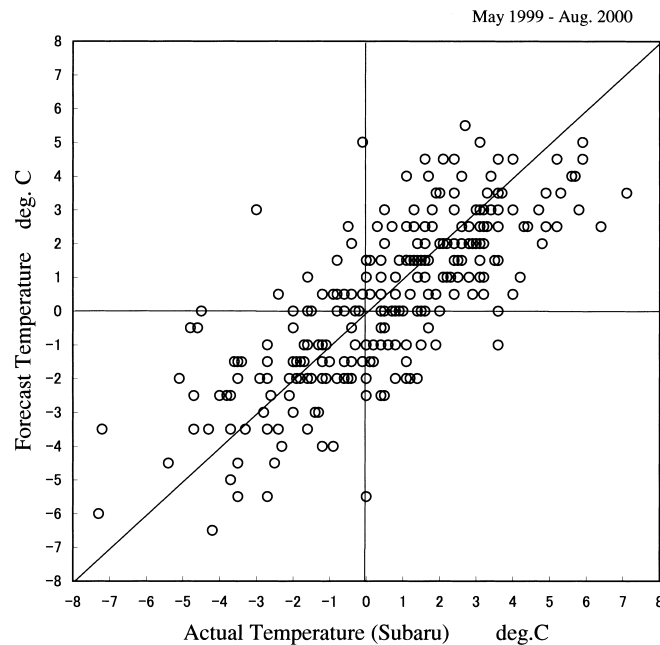

Fig. 1. Forecast temperature for Mauna Kea (4200 m) v.s. Actual temperature of Subaru site (4139 m).

morning.

The Mauna Kea Weather Center (MKWC) started to re-release ‘Forecast for Mauna Kea Observatories’ in January 1999, and numerical weather forecasting began July 1999. The weather forecast for specific times, 2:00, 14:00, and 20:00 (HST), for the next 3 days includes general weather information, precipitable water, air temperature at 4200 m elevation, wind directions and speed at elevations ranging from 4200 m to 16500 m. The forecast is updated at 10:00 and 17:00 (HST) every day except for weekends.

The ‘Forecast for Mauna Kea Observatories’ issued on the MKWC website is shown in Table 1. Temperature, wind

data, precipitable water in the upper atmosphere of the Mauna Kea, and the correlation coefficient of refractive index,  $C_n^2$  which shows the strength of turbulence as a function of the altitude are also shown. The seeing value is calculated by integrating  $C_n^2$  coefficients (Businger et al. 2002).

### 3. Comparison between Forecast and Actual Subaru Site Temperature

Data of actual night-time temperature (2:00 am HST) collected from ‘Subaru Weather Tower’ and the temperature predicted by MKWC are shown in Figure 1.

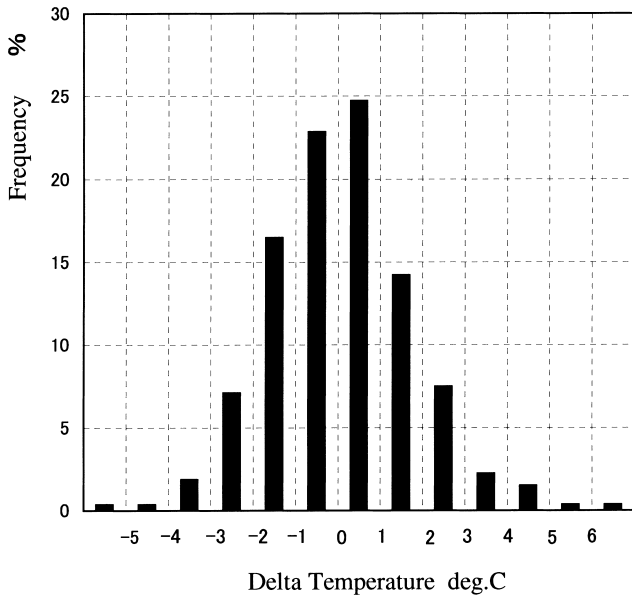

Fig. 2. Histogram of difference between forecasted temperature (corrected from 4200 m to 4139 m : + 0.4 deg.) and actual Subaru site (4139 m) temperature at 2:00 a.m. (HST) in May 1999 to Aug. 2000. Delta Temperature = Forecast Temperature + 0.4 – Actual Temperature.

The histogram of the difference between the forecast and the actual temperature is shown in Figure 2. The forecast temperature is corrected +0.4 degree centigrade by difference of altitude between at Summit (4200 m) and Subaru site (4139 m).

Comparing air temperature data from the 'Forecast for Mauna Kea Observatories' with those collected from 'Subaru Weather Tower', we found differences of less than  $\pm 1$  degree centigrade in 50% of the data points and less than  $\pm 2$  degrees centigrade in 80% of the data points. We supposed the forecast data made good use by the temperature control for the primary mirror of Subaru Telescope.

#### 4. Function of the Cooling Systems

##### 4.1 An algorithm for temperature control

An algorithm for temperature control is shown in Figure 3. There are two feedback loops. The inner feedback loop controls the air temperature (ambient) blown onto the primary mirror. The outer feedback loop controls the temperature of the primary mirror itself. To prevent dew condensation on the mirror cover and cell, the command value for the air blown onto the mirror is limited so that it is not lower than the dew point temperature.

A block diagram of the heat exhaust system of Subaru Telescope is shown in Figure 4. During the day-time, the pri-

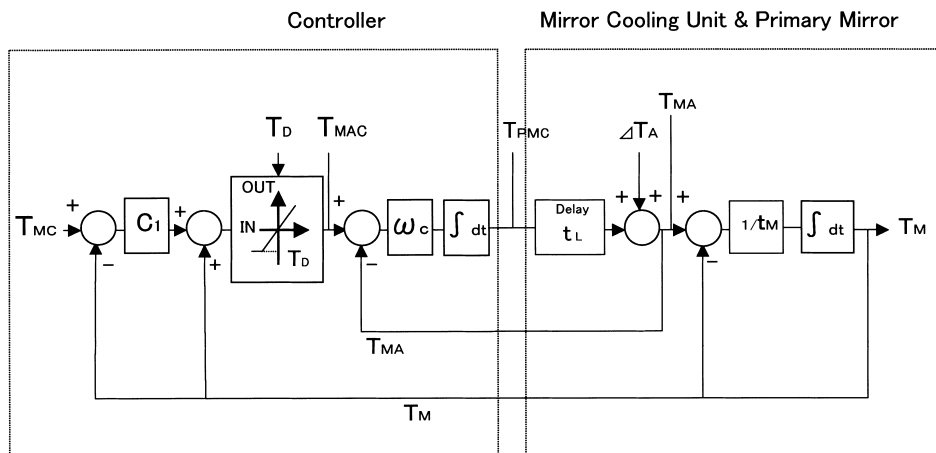

Fig. 3. An algorithm for temperature control.

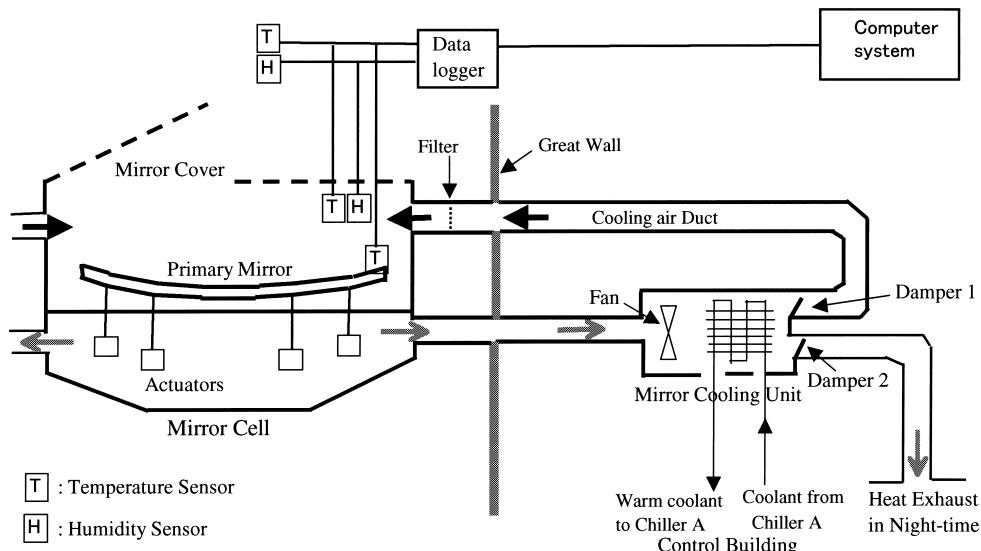

Fig. 4. A block diagram of the heat exhaust system of Subaru Telescope.

primary mirror's temperature is controlled by a command value that is set manually by 'Day Crew'. It is determined from MKWC forecast data (After March 2002, it is set automatically by the computer systems). To cool down or heat up the mirror, cool or warm air is blown onto the primary mirror. All mirror covers are closed, the air is circulated by opening 'Damper 1' and closing 'Damper 2'. The temperature of the coolant provided from the control building for 'Mirror Cooling Unit' is controlled by the computer systems.

The setting command value is by 2 degrees centigrade lower than a predicted temperature at 2:00 a.m. HST using the 10:00 a.m. HST forecast (lead time 16 hours).

The mirror ambient temperature control command value is calculated as follows.

$$T_{MAC} = (T_{MC} - T_M) \times C_1 + T_M \quad (1)$$

$$\text{If } T_{MAC} < T_D \text{ then } T_{MAC} = T_D \quad (2)$$

$$\text{If } T_{MAC} \geq T_D \text{ then } T_{MAC} = T_{MAC} \quad (3)$$

The coolant temperature control command value is calculated as follows.

$$T_{PMC} = T_{PMC'} + (T_{MAC} - T_{MA}) \times \omega_c \times \Delta t \quad (4)$$

$$\text{If } T_{PMC} < T_D \text{ then } T_{PMC} = T_D \quad (5)$$

$$\text{If } T_{PMC} \geq T_D \text{ then } T_{PMC} = T_{PMC} \quad (6)$$

$T_{MAC}$  : Mirror ambient temperature control command

$T_{MC}$  : Mirror temperature control command (Predicted night-time temperature - 2deg.C)

$T_M$  : Present mirror temperature (average of 4 point sensors on back-surface)

$T_D$  : Calculated due point temperature from relative humidity

$T_{PMC}$  : Coolant temperature control command

$T_{PMC'}$  : Previous calculated  $T_{PMC}$

$T_{MA}$  : Present mirror ambient temperature (average of two sensors in the mirror cell)

Parameters of Controller

$C_1$  : Mirror temperature control gain

To be adjusted. As initial value was 10, this was suit-

able. This parameter governs time constant of mirror temperature control. In case of  $C_1 = 10$ , mirror temperature time constant is  $t_M \cdot C_1^{-1}$  (approx. 1 hour) where  $t_M$  is the thermal time constant of mirror.

$\omega_c$  : Mirror ambient temperature control gain

To be adjusted taking into account  $t_L$ , time delay of the control of coolant temperature by the pump system. As initial value, 0.0011 (this means time constant is 15 minutes=900 seconds= $\omega_c^{-1}$ ).

$\Delta t$  : Cycle of calculation (As initial value, 1 second)

Parameters of mirror cooling unit and primary mirror

$t_L$  : Time delay of the control of coolant temperature by the pump system ~ 5 min.

$\Delta T_A$  : Temperature rise due to mirror support actuators ~ 10

$t_M$  : Thermal time constant of the primary mirror calculated by  $t_M = mch^{-1}s^{-1}$  ~ 10 hours, where

$m$  : mirror's mass 25,000 kg

$c$  : mirror's specific heat  $685 \text{ J} \cdot \text{kg}^{-1} \cdot ^\circ\text{C}^{-1}$

$h$  : heat transfer coefficient between air and mirror  $4.3 \text{ W} \cdot \text{m}^{-2} \cdot ^\circ\text{C}^{-1}$

$s$  : surface area of the primary mirror  $108 \text{ m}^2$

#### 4.2 Heat exhaust for mirror cell

During the night-time, all mirror covers are opened. And outside ambient air is introduced inside the mirror cell. 'Damper 1' is closed and 'Damper 2' is opened, the warmed air caused by the mirror support actuators is cooled by the mirror-cooling unit and expelled outside the enclosure through the ventilation floor.

#### 4.3 Analysis

The temperature variation in three days of the ambient air and the primary mirror after the control of the temperature is shown in Figure 5. The ambient air temperature of the primary mirror repeated to cool down and heat up by the command value. And then the surface temperature of the primary mirror is also down and up, finally it is close to the command

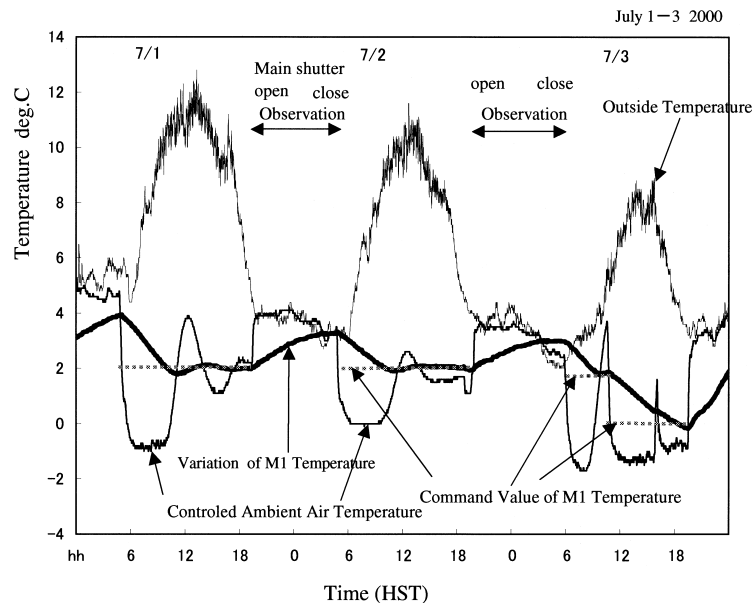

Fig. 5. Temperature variations by the cooling system.

value using the forecast. The primary mirror temperature is 2 degrees centigrade lower than the ambient air temperature at the time of starting observation, and it is close to ambient air temperature on the following morning.

The required time for cool down the primary mirror to command temperature is shown in Figure 6.

To cool down the mirror 1 degree, 2 degrees, and 3 de-

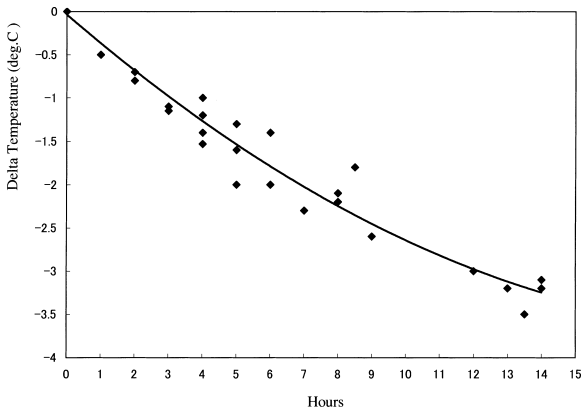

Fig. 6. Required time for cool down the primary mirror to command temperature.

grees centigrade requires 3 hours, 7 hours, and 12 hours, respectively.

These data were taken under the most ideal conditions. All mirror covers were closed and the telescope elevation angle was at an angle of 90 degrees throughout the day time. The telescope elevation angle at any other angle will not allow the heat exhaust system to circulate air in the mirror cell.

Based on the data from the Subaru weather monitor tower in 1999, 76% of the outside air temperatures (at 2:00 a.m. HST) are within  $\pm 2$  degrees of those of the night before. Therefore, if the command value is set on the cooling system before noon, in accordance with the 10:00 a.m. (HST) MKWC forecast, the mirror can be cooled down in time for observation.

Thus we started to operate the temperature control of the Subaru Telescope primary mirror based on the data from MKWC forecast since May 2000.

Actual temperatures of the primary mirror and ambient air (at 2:00 a.m. HST on observing night) in January to August 2000 are shown in Figure 7. The histogram of difference of temperature between primary mirror and ambient air temperature are shown in Figure 8.

After the start of operation, the temperature of the pri-

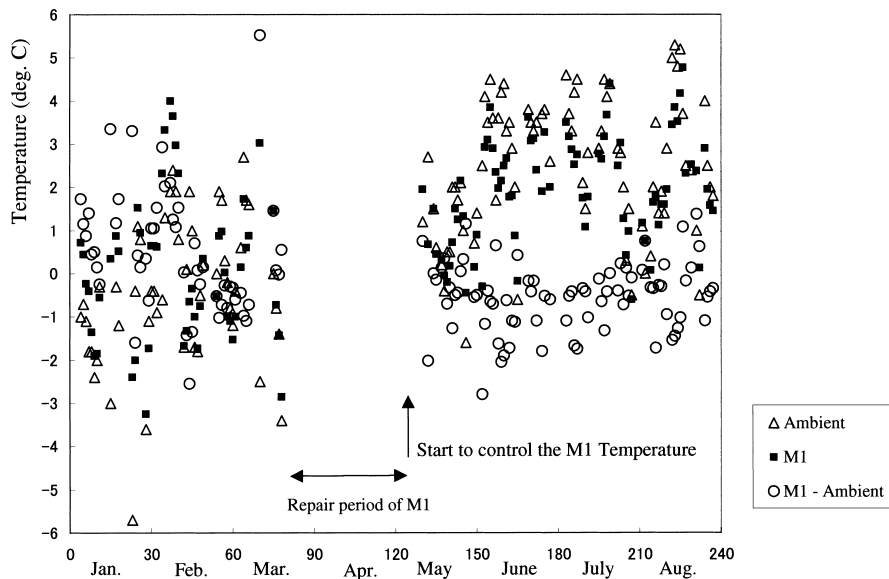

Fig. 7. Actual primary mirror and ambient air temperature at 2:00 a.m. on January to August in 2000.

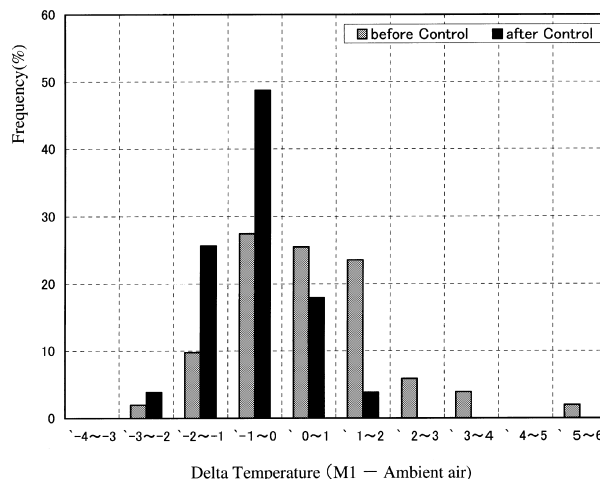

Fig. 8. Histogram of difference of temperature between primary mirror and ambient air temperature at 2:00 a.m.



primary mirror controlled below 1 degree centigrade compared by the ambient night air temperature in over 70% probability.

In early period, the command value of mirror temperature was set manually every day before noon by Day-Crew, but after March in 2002, it was set automatically by computer system at 10:30 a.m. using the forecast data on MKWC web-site.

We expected the improvement of the seeing of Subaru Telescope by the effect of the temperature control of the primary mirror.

## 5. Seeing statistics

### 5.1 Seeing Measurement by images from 'Auto Guider'

The full width at half maximum (FWHM) seeing size of the Subaru Telescope measured from images by the 'Auto Guider (AG)' in the red band during focus check has been compiled two or three times on the every observing nights by the telescope operator since 1999.

The histogram of seeing (FWHM) for non-controlled period of primary mirror temperature in January to March 2000 and for the controlled period on same month in 2001, 2002 and 2003 are shown in Figure 9.

The statistics on seeing (FWHM) for after temperature

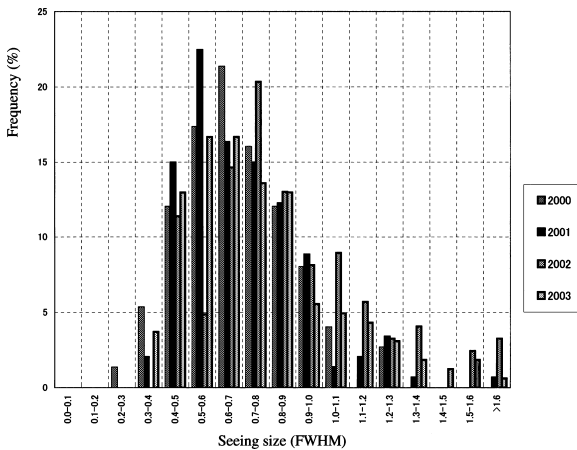

Fig. 9. Histograms of seeing size on January to March for non-controlled temperature of M1 in 2000, and for controlled period in 2001, 2002 and 2003.

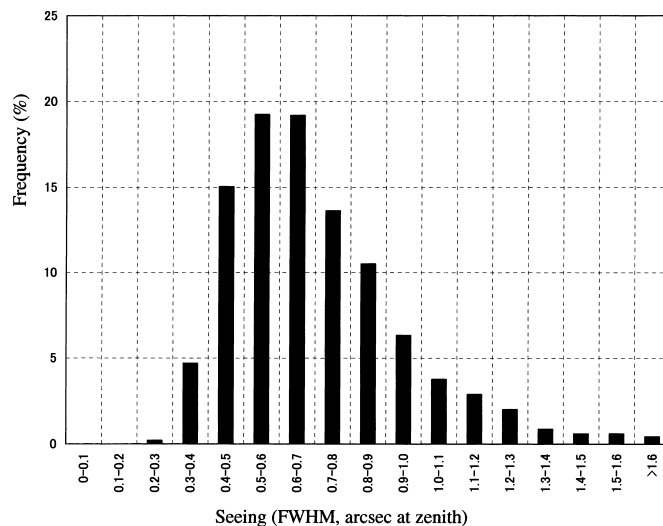

Fig. 10. Histogram of seeing size for after M1 temperature controlled period in May, 2000 to March, 2003.

controlled in 2001 seems to be improved by the amount of 0.1 arcsec compared by non-controlled period in 2000. But seeing (FWHM) in 2002 are not good because of the weather conditions.

The histogram of seeing (FWHM) for primary mirror temperature controlled period from May 2000 to January 2003 is shown in Figure 10. The median of the seeing (FWHM) is 0.655 arcsec.

## 6. Conclusion

Based on the successful numerical weather forecasting performed by collaboration between MKWC and Subaru Telescope, we developed a temperature control system of the primary mirror of the Subaru Telescope.

The heat exhaust system has several possible reasons to consider. The coolant warms as it travels through the insulated piping from the first floor of control building to the observing floor of the enclosure. As a result, sometimes the ambient and mirror temperatures are not lowered enough.

However, there is enough time for the primary mirror to reach its command value temperature before starting night observations. The mirror temperature stabilizes to within 0.1 degree centigrade of the command value,  $\pm 2$  degrees centigrade, in approximately six hours. The mirror heat exhaust control satisfies the required time of eight hours.

After the start of operation, the temperature of the primary mirror controlled below 1 degree centigrade compared by the ambient night air temperature in over 70% probability.

The effect of the temperature control for the improvement of the seeing of Subaru Telescope seems to be moderately effective. But we need further investigation as to whether the improvement is the result of our successful temperature control system of the primary mirror, or the effect of the annual variation of seeing itself. Thus, we need a longer period of data for verification of the effectiveness of the temperature control.

The authors wish to thank Drs. Toshiyuki Sasaki, Tadamichi Takata, George Kosugi, Tomonori Usuda, Naruhisa Takato and Junichi Noumaru for supporting our work. Thanks are due to Subaru Telescope operators who made the measurement of seeing (FWHM) every night, and also due to Subaru Telescope Day Crew team who manually set the command for temperature control of the primary mirror.

### References

- Iye, M., Noguchi, T., Torii, Y., Mikami, Y. and Ando, H. 1991, "Evaluation of Seeing on a 62cm Mirror", *Publ. Astron. Soc. Pacific*, **103**, 712–722.
- Businger, S., Ogasawara, R., MacLaren, L., Simon, D. and Wainscoat, R. 2002, "Stellar Viewing Forecasting for Hawaii's Mauna Kea Observatories", *Bulletin of the American Meteorological Society*, **83**, 858–871.
- Uraguchi, F., Takato, N., Miyashita, A., Yanagisawa, K. and Okada, N. 2002, "DIMM with large aperture separation and simultaneous seeing measurement at Mauna Kea", *Proc. SPIE*, **4837**, 864–871.
- Miyashita, A., Ogasawara, R., Takato, N., Kosugi, G., Takata, T. and Uraguchi, F. 2002, "Temperature Control for the Primary Mirror and Seeing Statistics of Subaru Telescope", *Proc. SPIE*, **4837**, 255–263.